

MİMARİ KATALOG
ARCHITECTURAL CATALOGUE

Alüminyum Konvansiyonel Sistemleri
Aluminium Conventional Systems

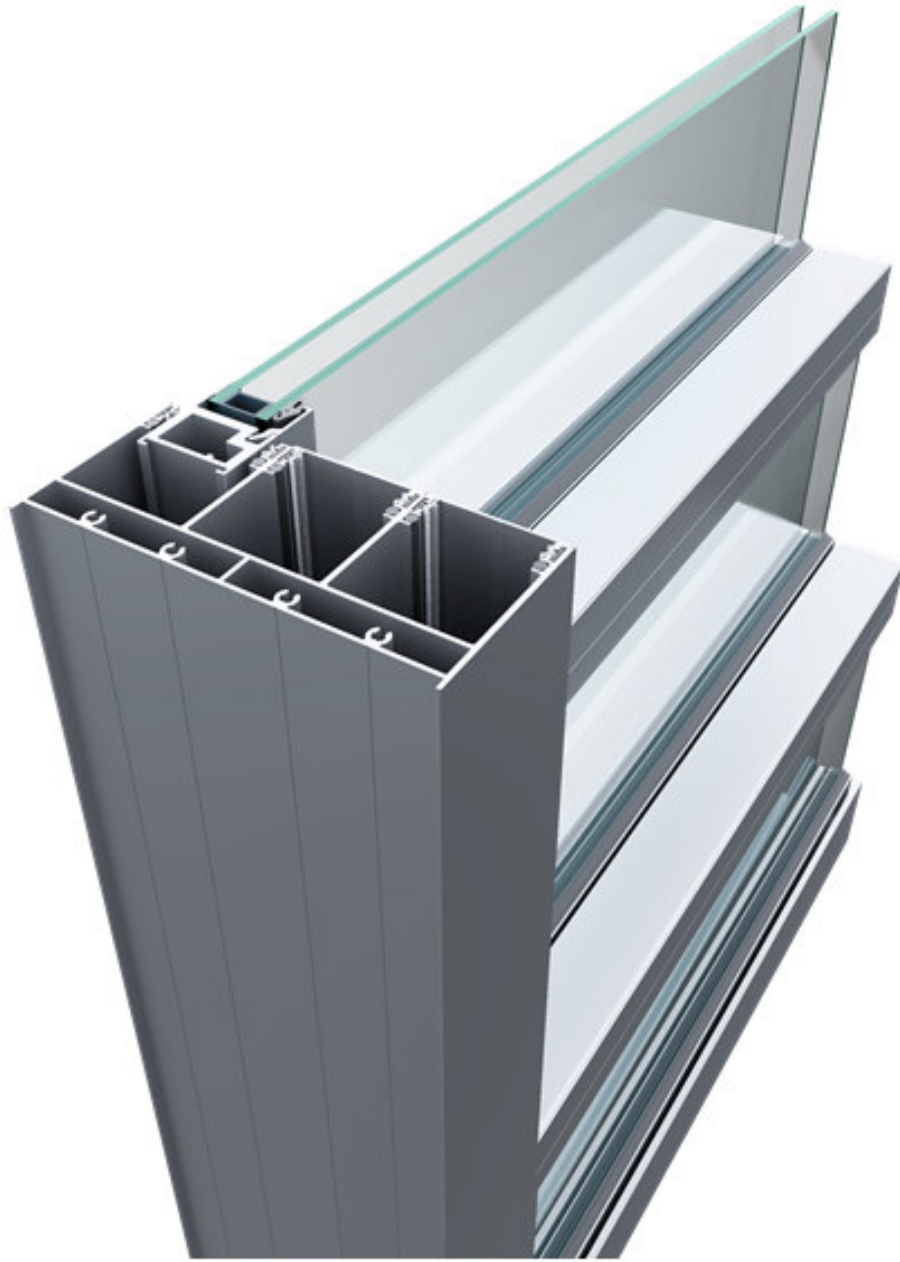

RGK35



TEKNİK ÖZELLİKLERİ / TECHNICAL PROPERTIES

MAX GENİŞLİK/ MAX WIDTH	3000 mm
MAX YÜKSEKLİK/ MAX HEIGHT	3000 mm
YÜK DAYANIMI / LOAD RESISTANCE	120 N/mt
MAX CAM KALINLIĞI/ MAX GLASS THICKNESS	Isıcam ve Tekcam Alternatifli

KULLANIM SEÇENEKLERİ / APPLICATION ALTERNATIVES

TEK CAM VE ÇİFT CAM ALTERNATİFLERİ / SINGLE AND DOUBLE GLAZING ALTERNATIVES
MOTORLU KULLANIM İMKANI / MOTOR USAGE POSSIBILITY

MİMARİ KATALOG
ARCHITECTURAL CATALOGUE

Alüminyum Konvansiyonel Sistemleri
Aluminium Conventional Systems

RGK35

PROFİLLER

PROFILES

KOD / CODE	AĞIRLIK (kg/m) / WEIGHT	L m	KOD / CODE	AĞIRLIK (kg/m) / WEIGHT	L m
GK35B01	3,587	6			
GK35B03	0,761	6			

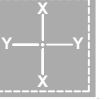

GK35B03

GK35B01

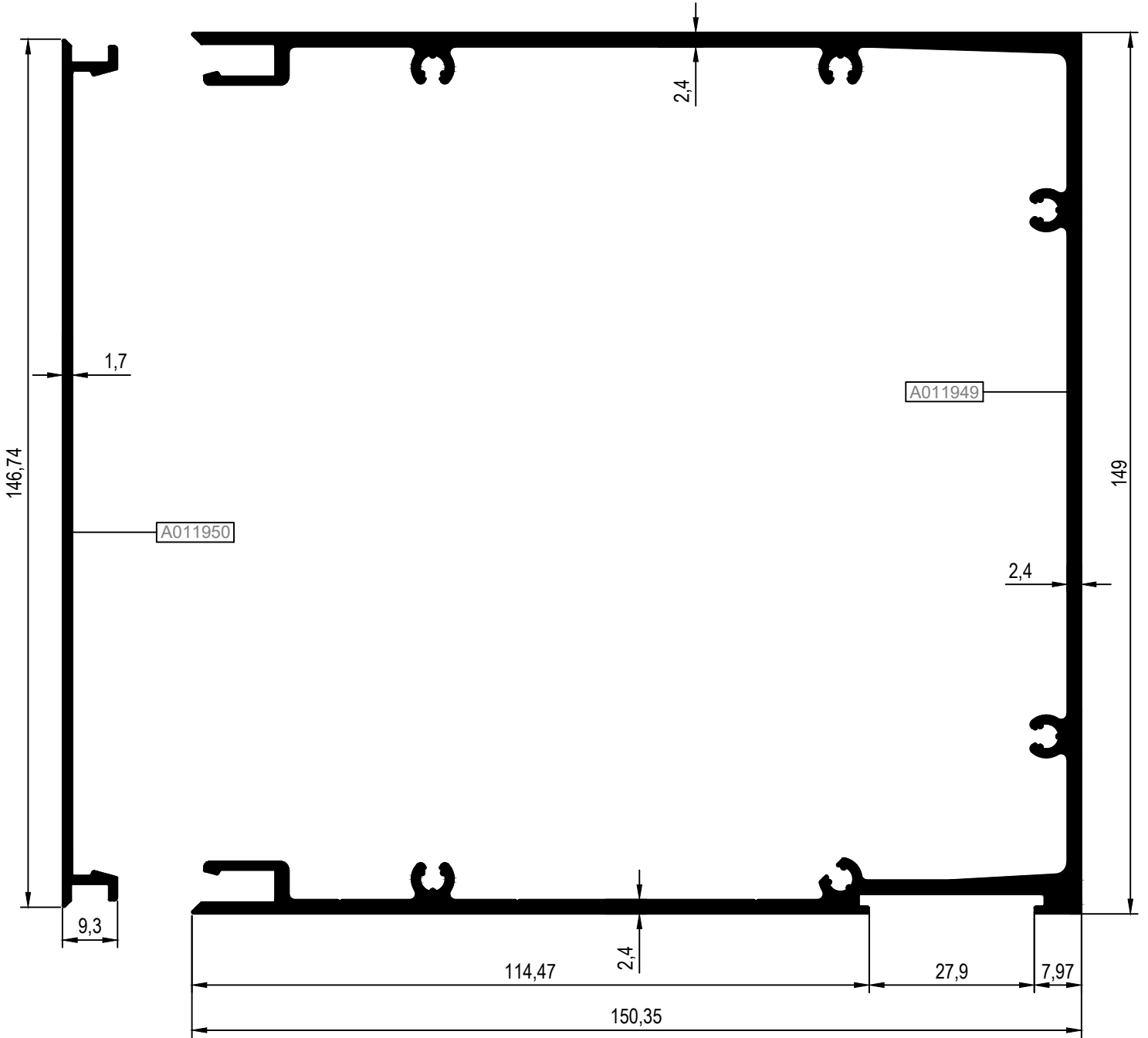

KOD / CODE	AĞIRLIK (kg/m) / WEIGHT	L m	KOD / CODE	AĞIRLIK (kg/m) / WEIGHT	L m
GK35F01	3,469	6			
GK35F02	2,066	6			



GK35F01

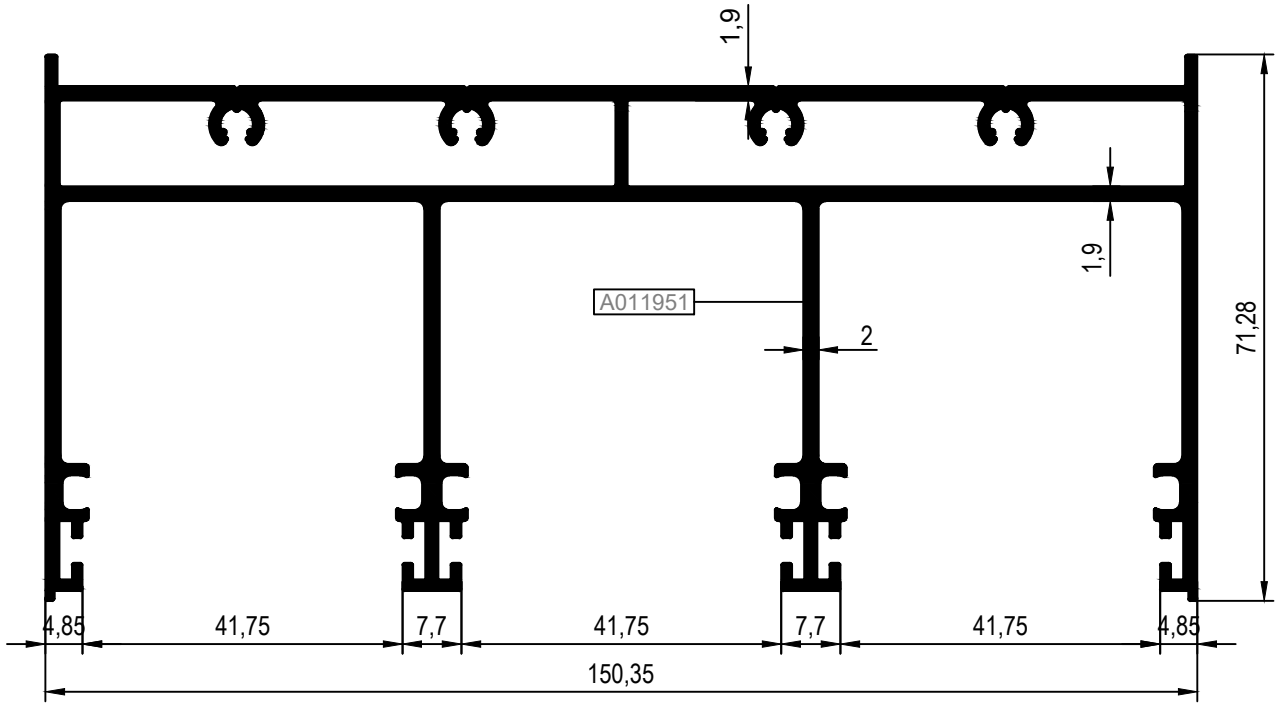

GK35F02

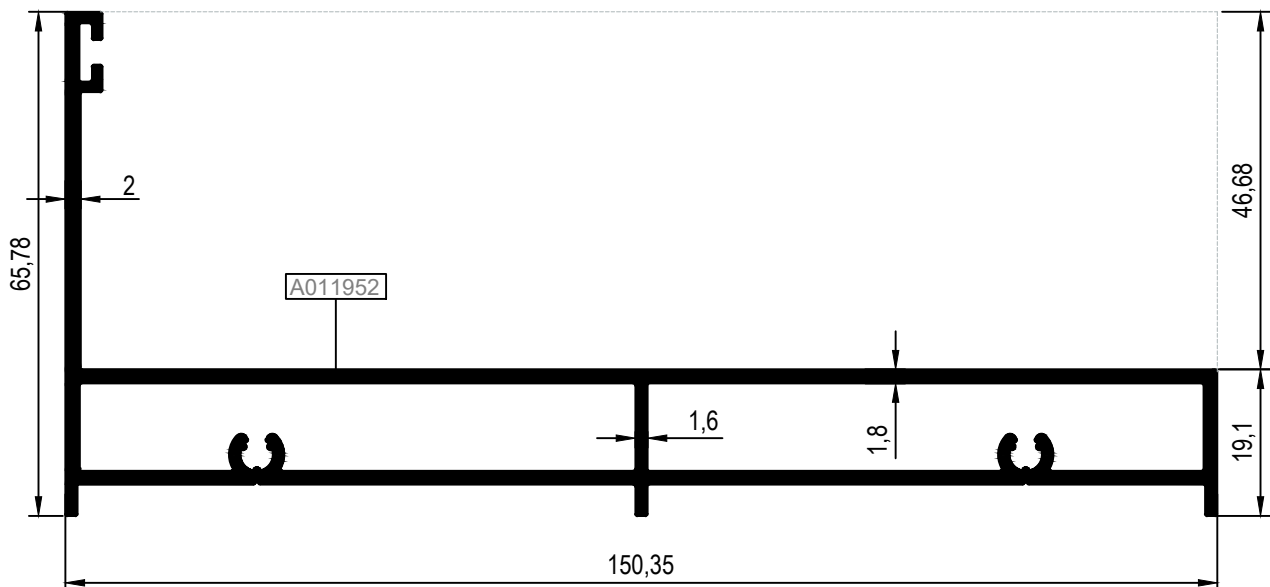

KOD / CODE	AĞIRLIK (kg/m) / WEIGHT	L m	KOD / CODE	AĞIRLIK (kg/m) / WEIGHT	L m
GK35A01	1,233	6	GK35A03	0,192	6
GK35V01	1,071	6			
GK35G01	0,149	6			
GK35A02	0,821	6			

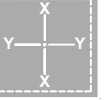

GK35 A 01

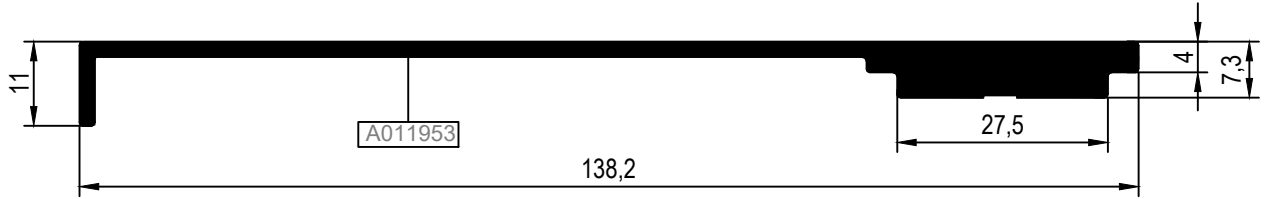

GK35V01

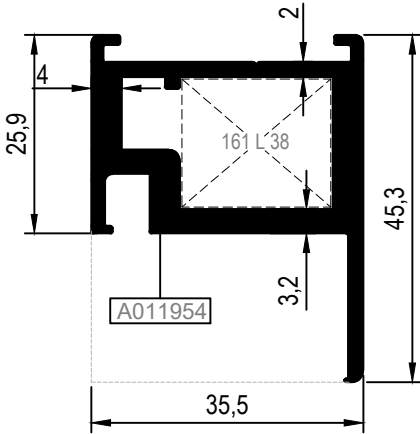

GK35G01

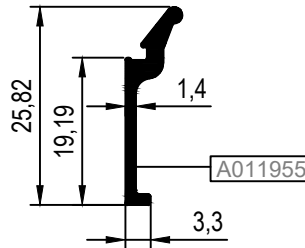

GK35A02

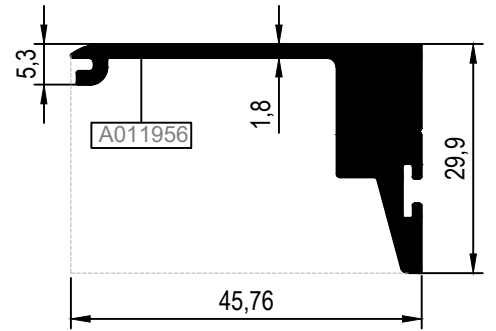

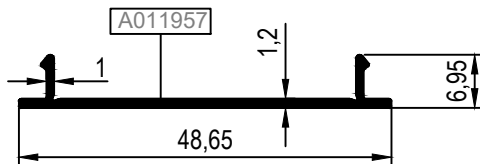

GK35A03

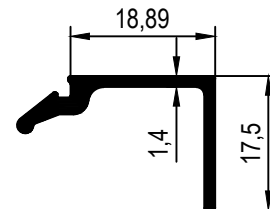

**GK35GXX





**Kalıp aktif değildir. Sipariş üzerine yapılacaktır.
The die is not active. It will be produced by order.

Nr		 L m	KESİM ÖLÇÜSÜ CUTTING SIZE	 AKS. KODU ACS. CODE
GK35V01	A011954	25L38(A002074)	19,4 mm	161 L 38

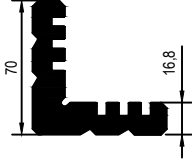
KÖŞE TAKOZLARI (CORNER CLEATS)

PROFİL KODU (PROFILE CODE)	25L38			
FABRİKA KODU(FACTORY CODE)	A002074			
AĞIRLIK (WEIGHT)	4,854 kg/m			
ÇİZİM (DRAWING)				

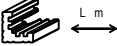
KÖŞE TAKOZLARI (CORNER CLEATS)

Nr			KESİM ÖLÇÜSÜ CUTTING SIZE	
GK35V01	A011954	25L38(A002074)	19,4 mm	161 L 38

MİMARİ KATALOG
ARCHITECTURAL CATALOGUE

Alüminyum Konvansiyonel Sistemleri
Aluminium Conventional Systems

RGK35

DETAYLAR

DETAILS

ÇİFT CAMLI DETAYLAR
DOUBLE GLAZED DETAILS

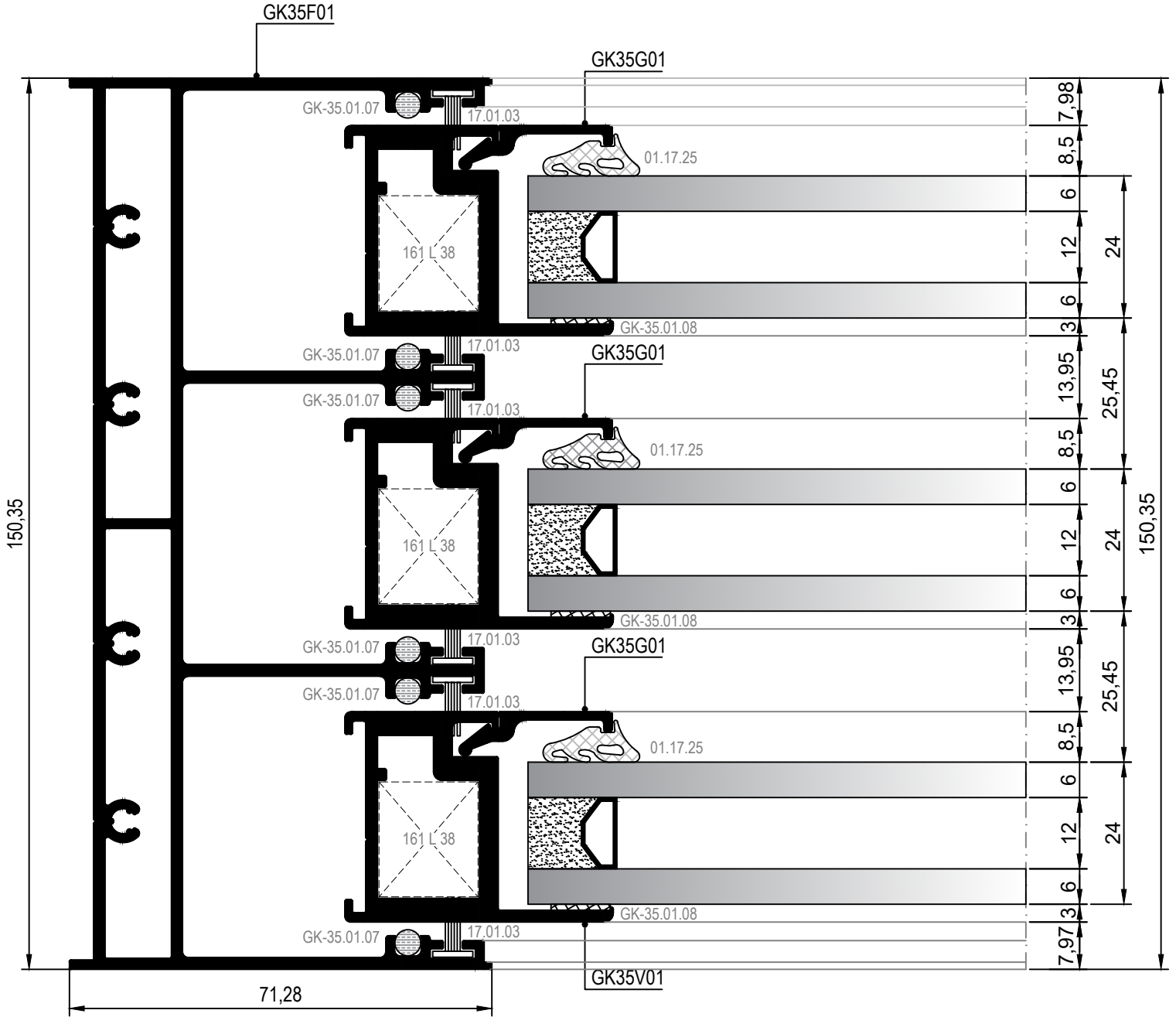
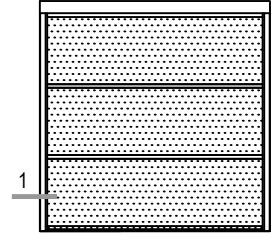

① DETAYI
DETAIL

ÇİFT CAMLI DETAYLAR
DOUBLE GLAZED DETAILS

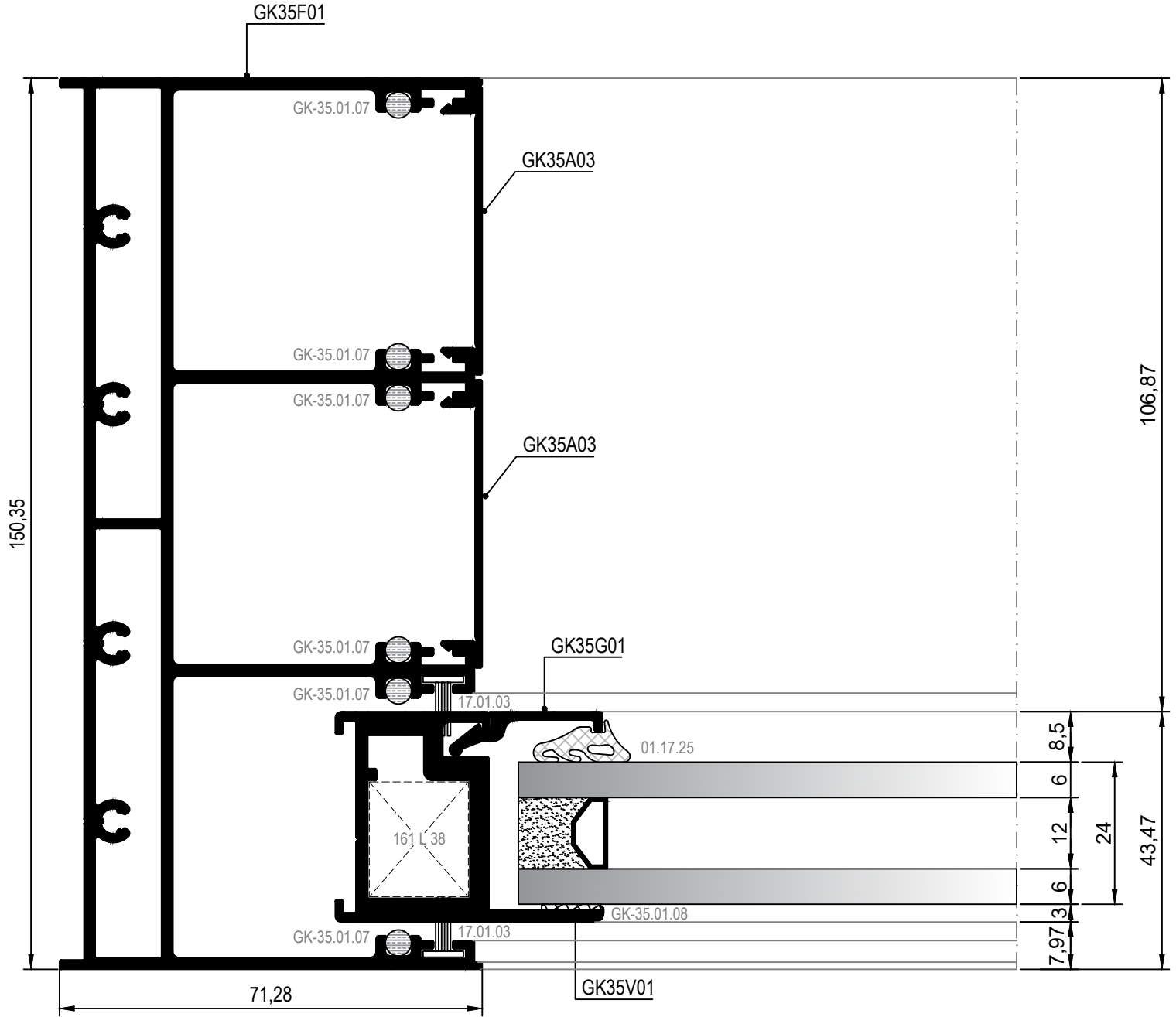
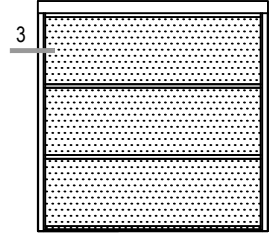

③ DETAYI
DETAIL

ÇİFT CAMLI DETAYLAR
DOUBLE GLAZED DETAILS

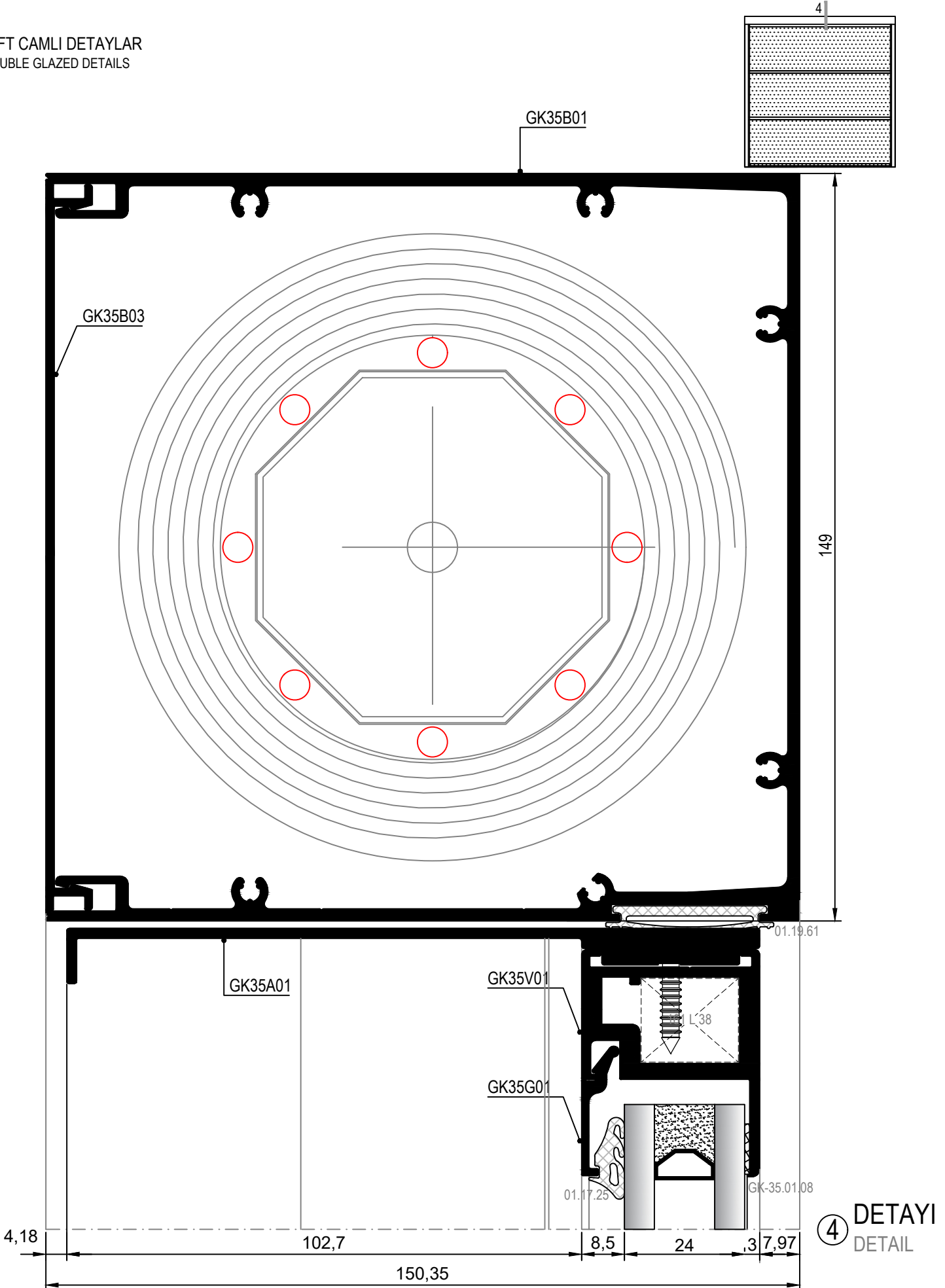

ÇİFT CAMLI DETAYLAR
DOUBLE GLAZED DETAILS

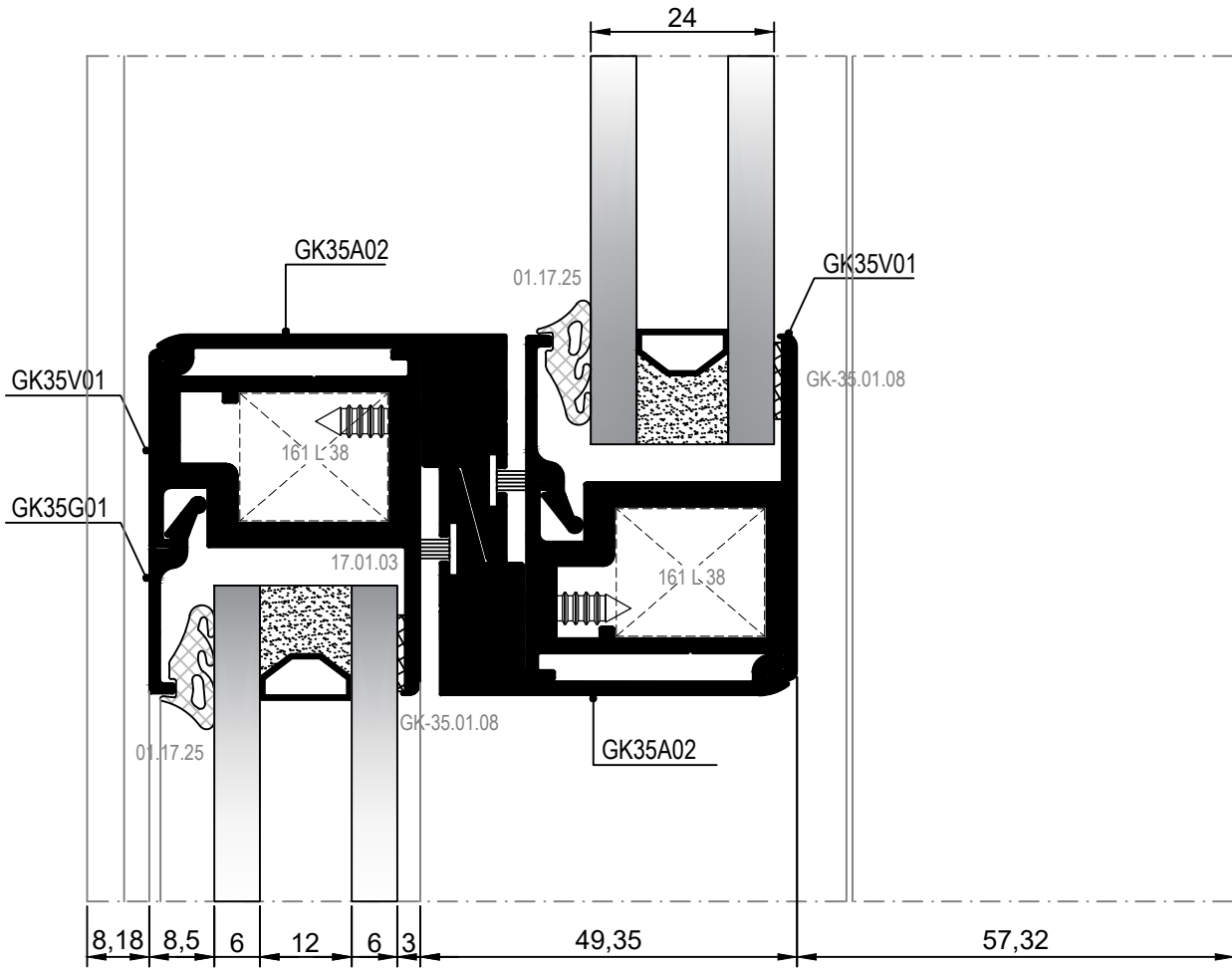
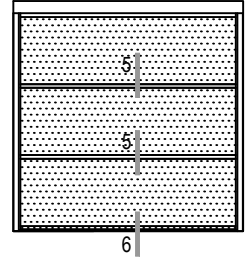

⑤ DETAYI
DETAIL

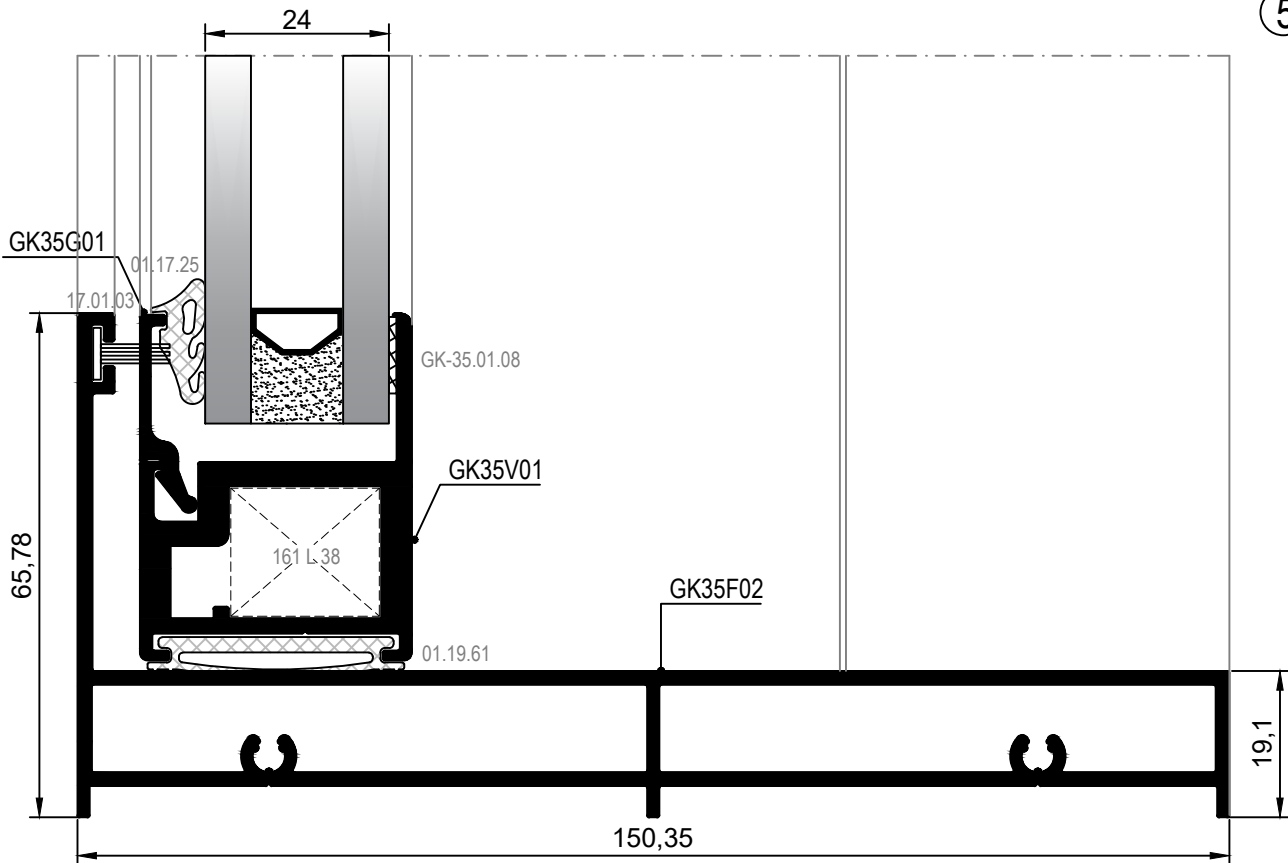

⑥ DETAYI
DETAIL

TEK CAMLI DETAYLAR (10 mm)
SINGLE GLAZED DETAILS (10 mm)

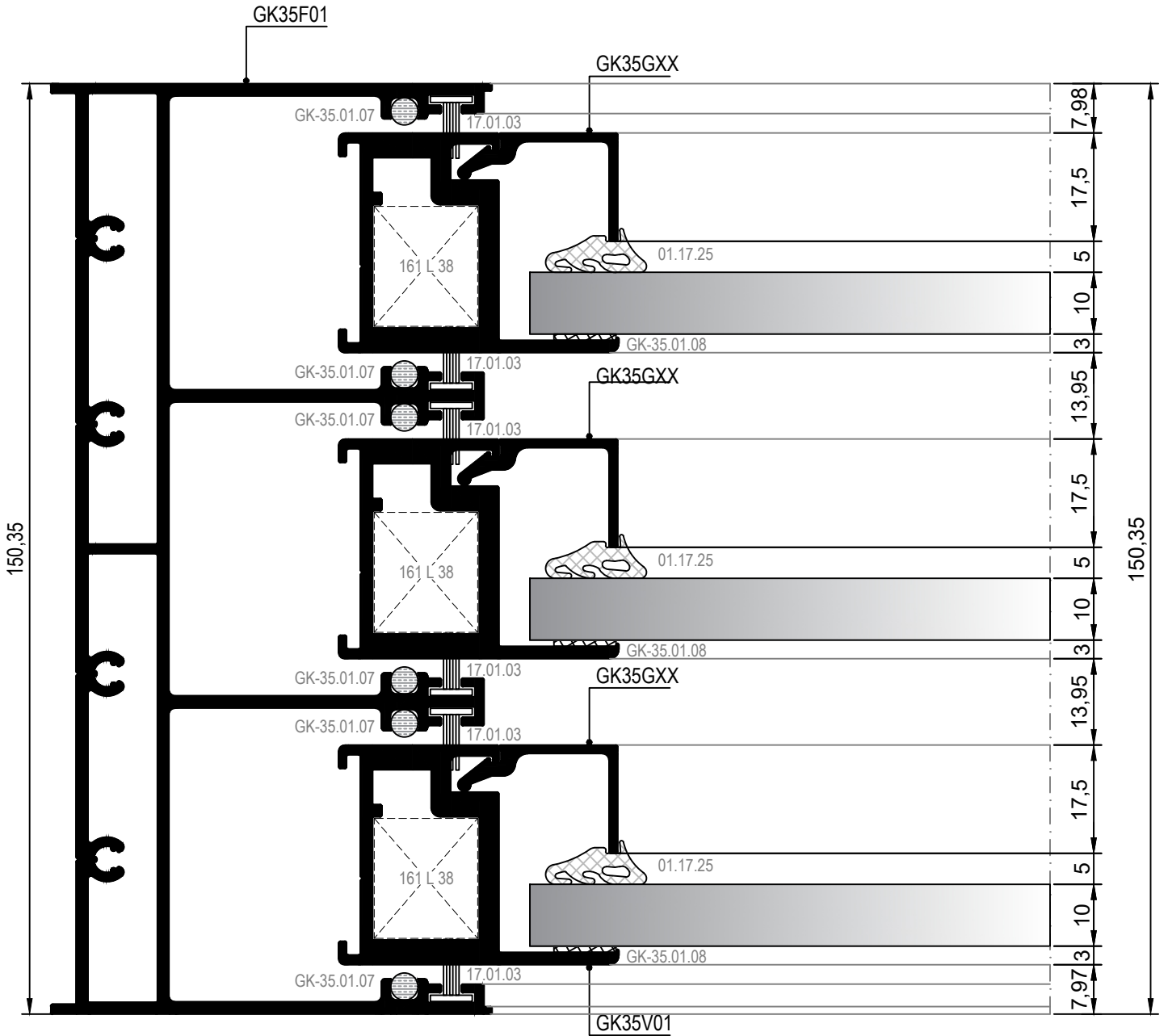
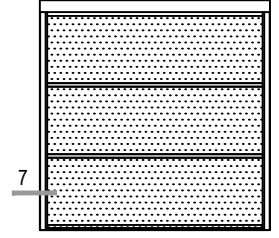

⑦ DETAYI
DETAIL

TEK CAMLI DETAYLAR (10 mm)
SINGLE GLAZED DETAILS (10 mm)

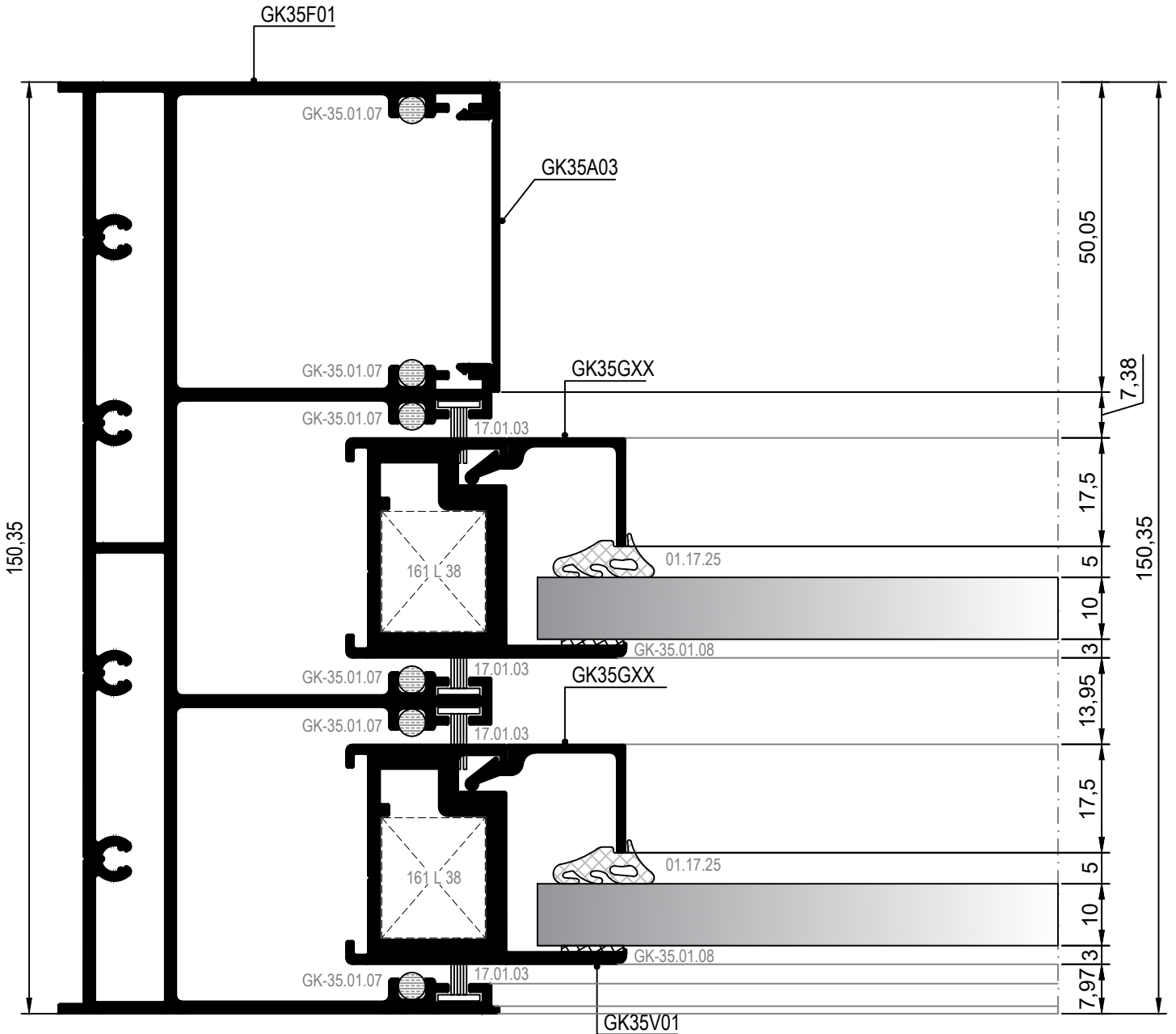
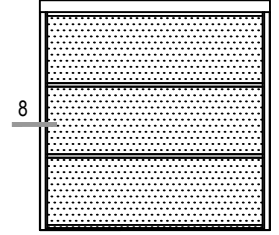

⑧ DETAYI
DETAIL

TEK CAMLI DETAYLAR (10 mm)
SINGLE GLAZED DETAILS (10 mm)

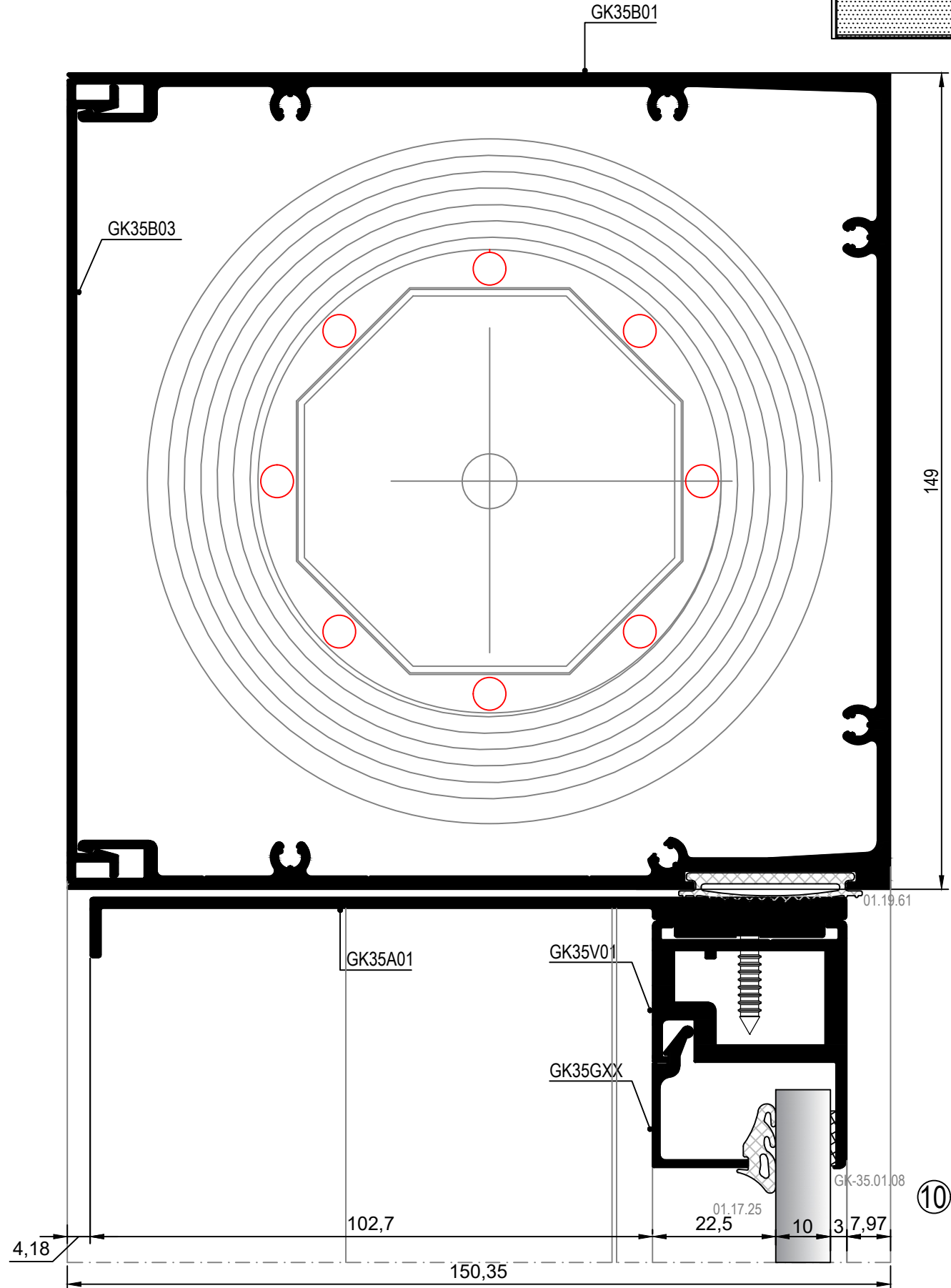
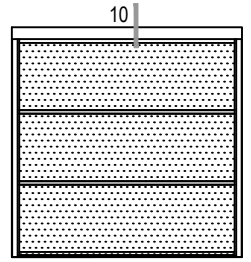

⑩ DETAYI
DETAIL

TEK CAMLI DETAYLAR (8 mm)
SINGLE GLAZED DETAILS (8 mm)

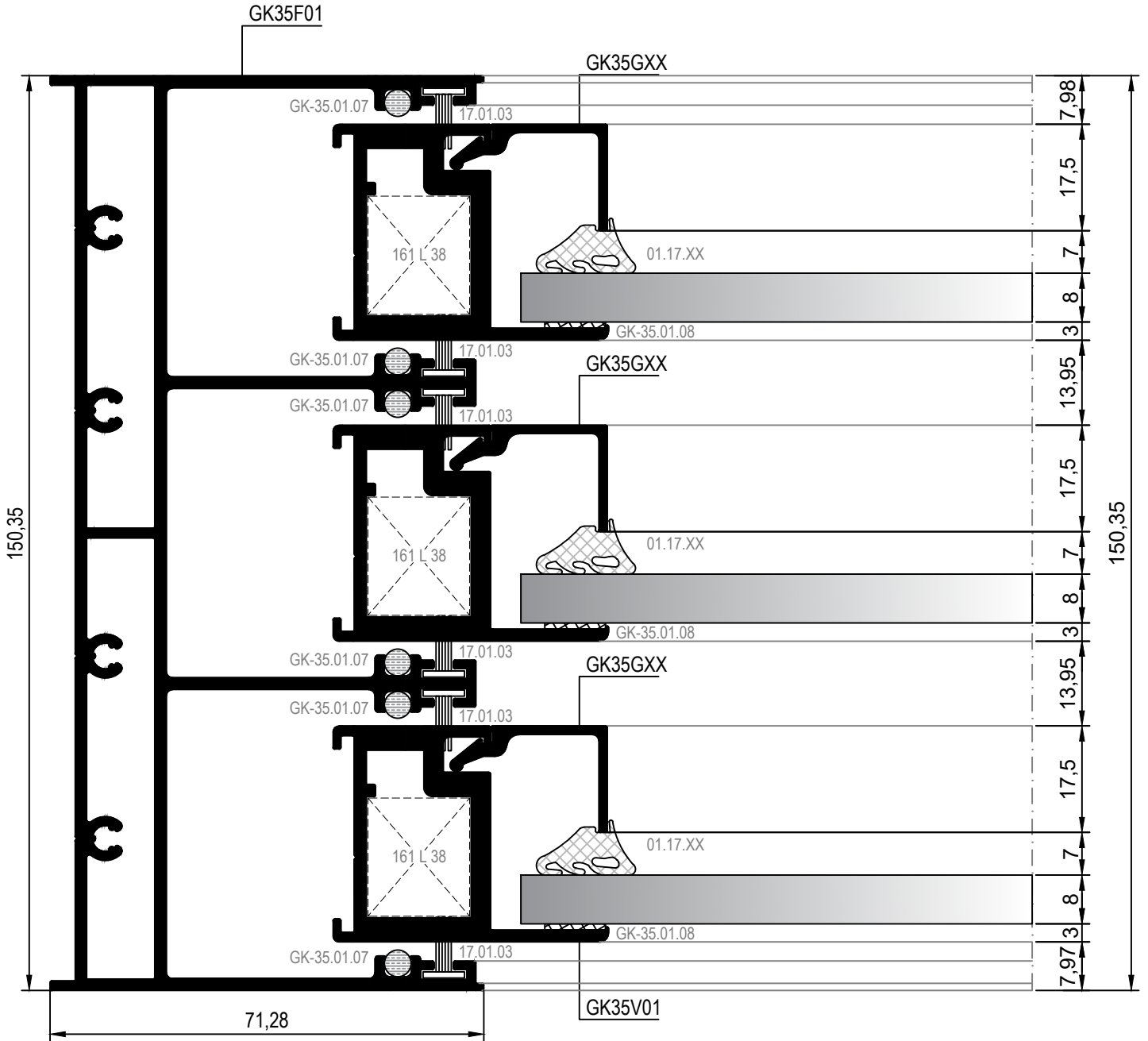
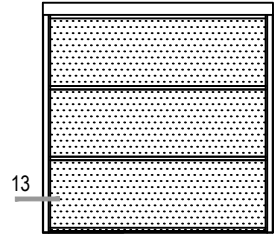

⑬ DETAYI
DETAIL

TEK CAMLI DETAYLAR (8 mm)
SINGLE GLAZED DETAILS (8 mm)

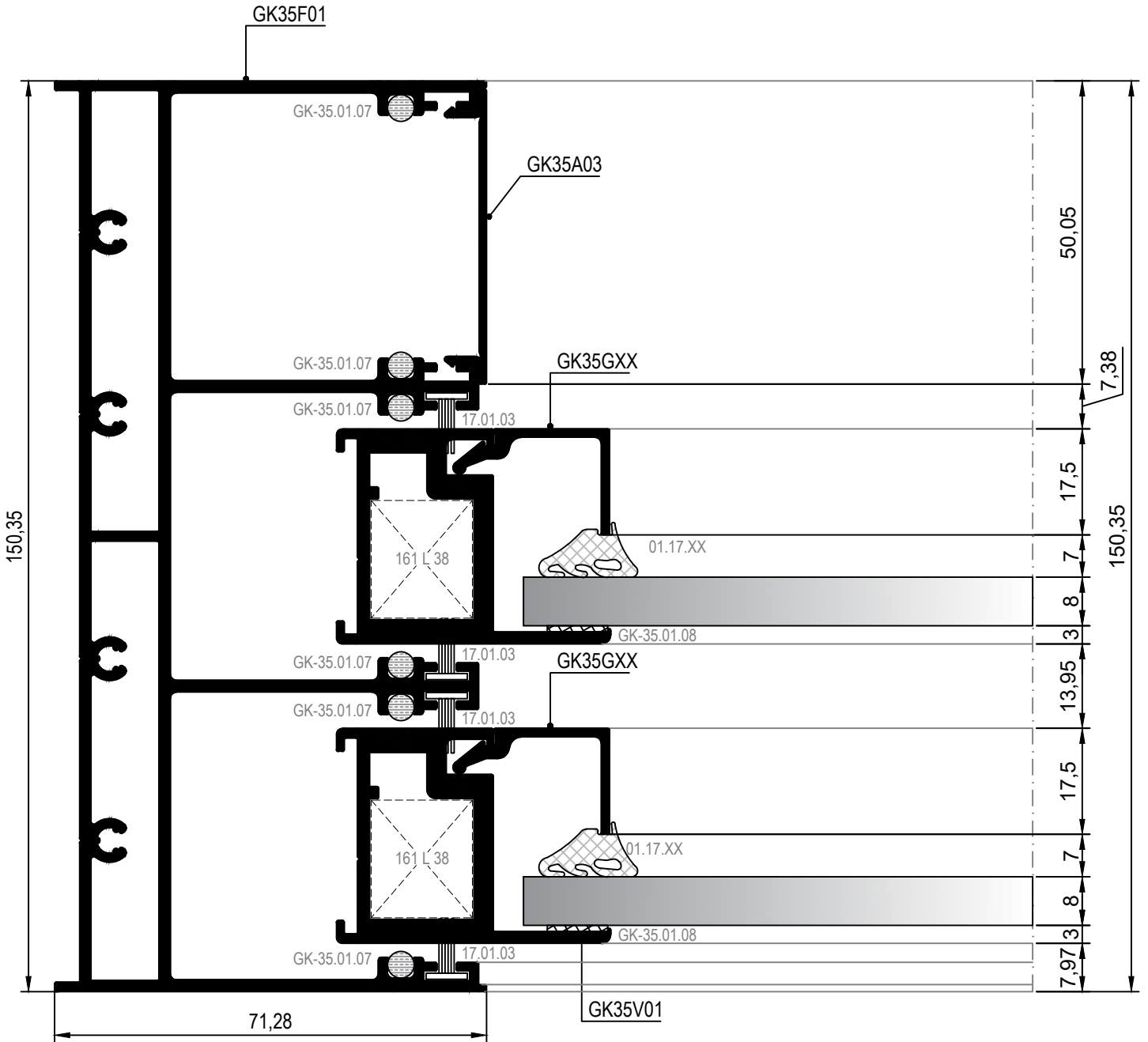
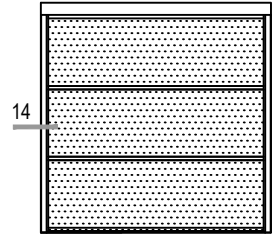

14 DETAYI
DETAIL

TEK CAMLI DETAYLAR (8 mm)
SINGLE GLAZED DETAILS (8 mm)

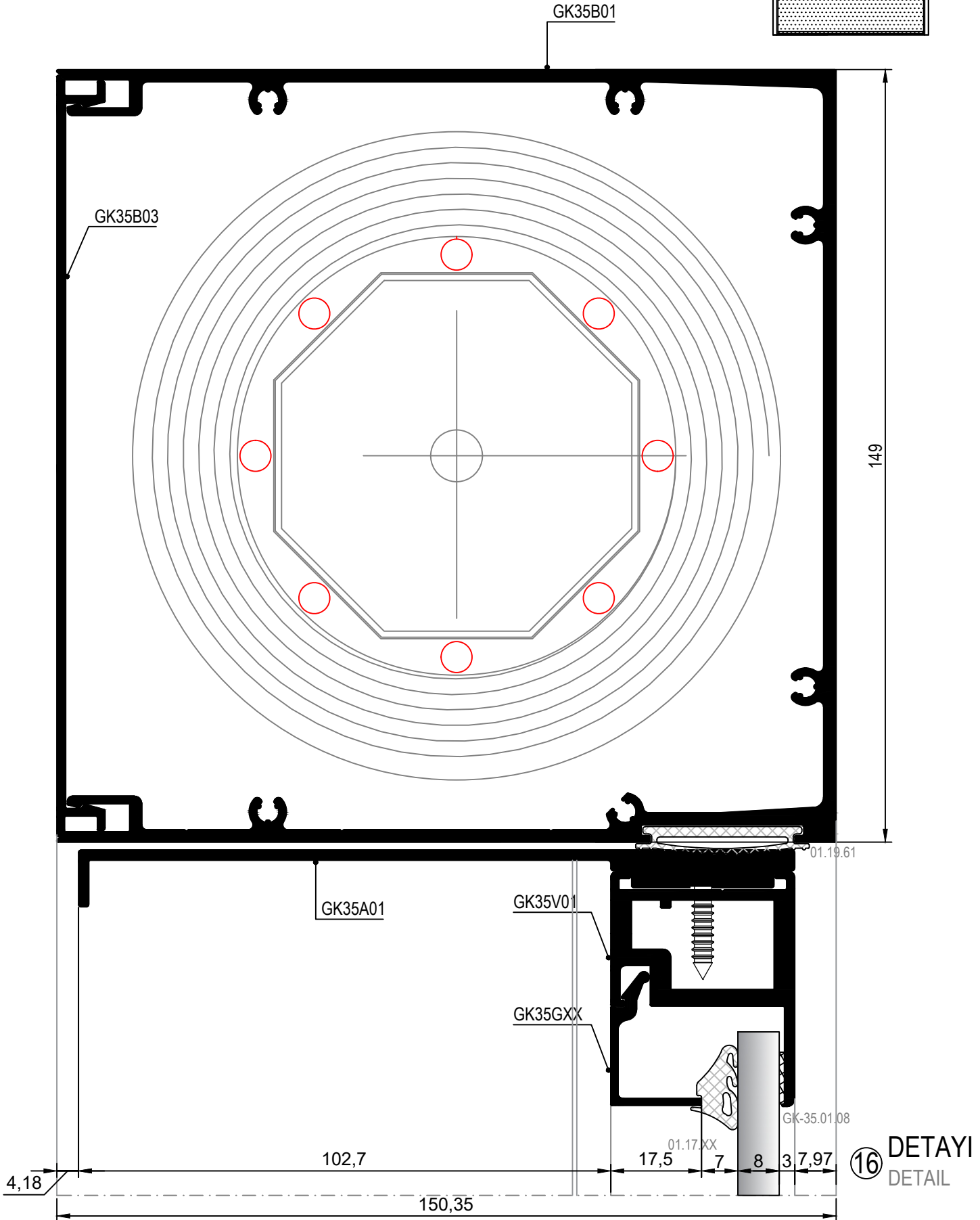
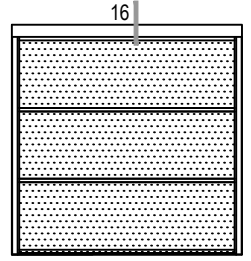

TEK CAMLI DETAYLAR (8 mm)
SINGLE GLAZED DETAILS (8 mm)

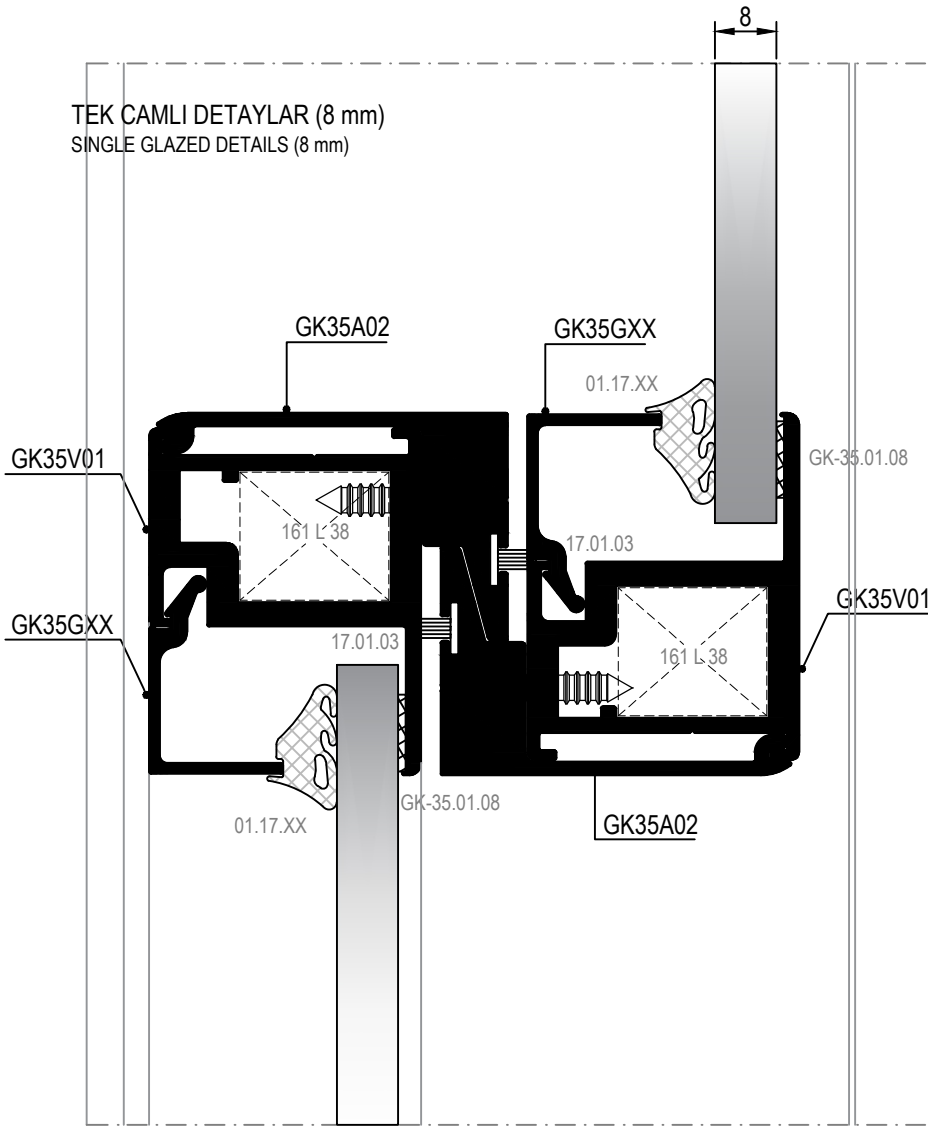

17 DETAYI
DETAIL

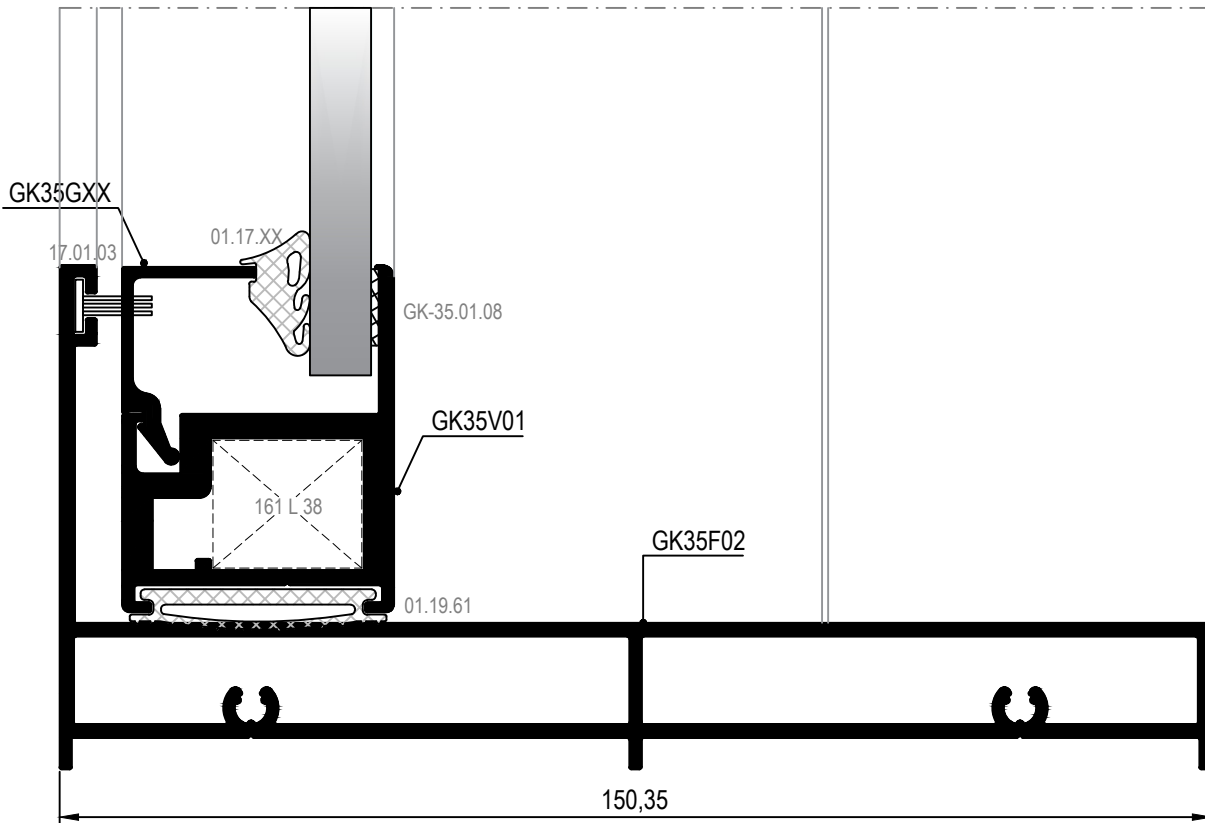

RGK35

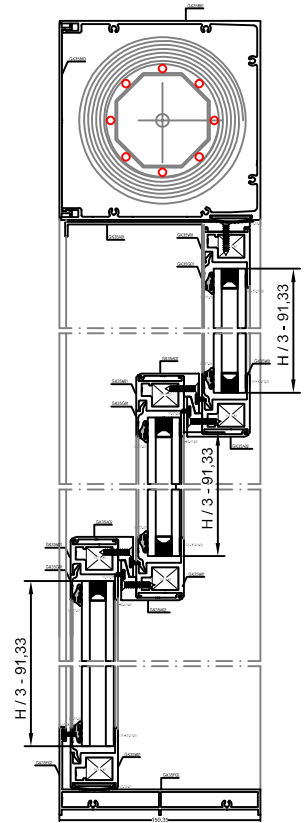
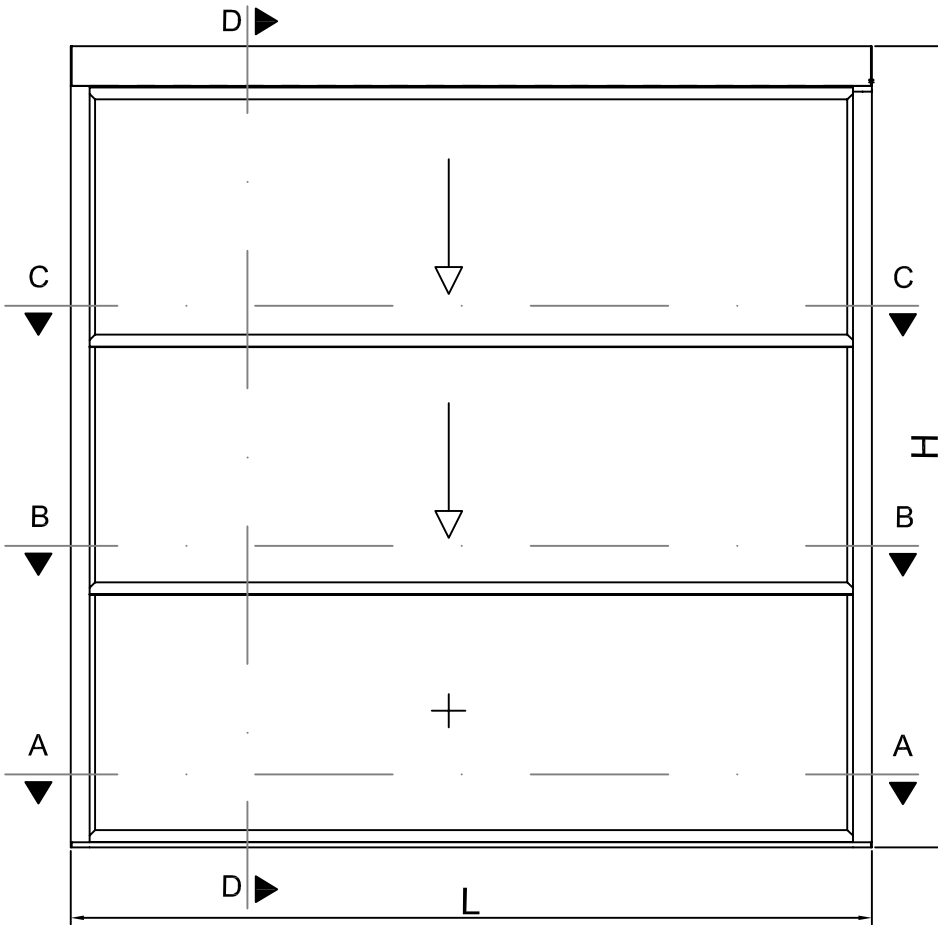

D-D Kesiti

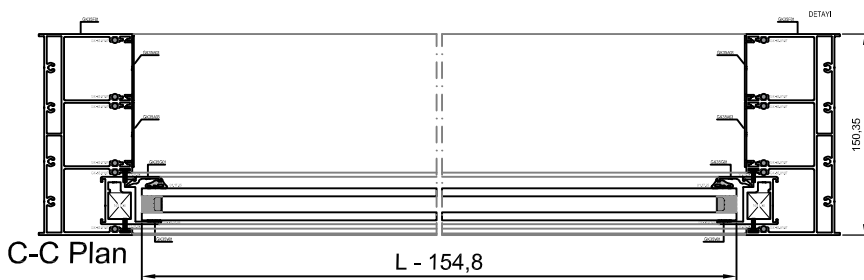
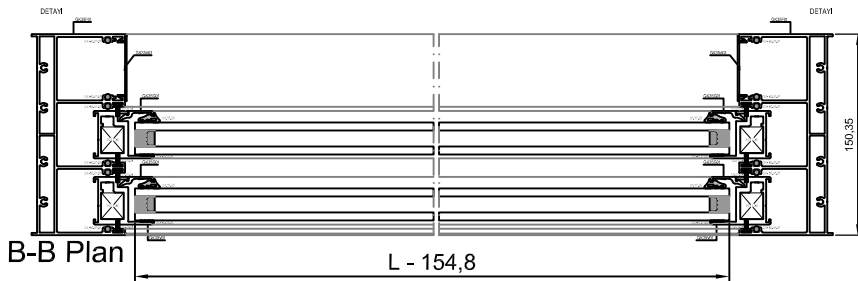
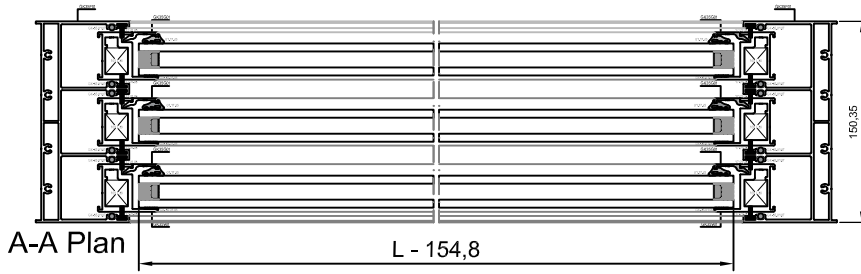

PROFİLLER / Profiles

KOD code	PROFİL profile	ADET unit	KESİM ÖLÇÜSÜ Cutting Dimension(mm)
GK35B01		1	L - 8
GK35B03		1	L - 8
GK35F01		2	H - 168,1
GK35F02		1	L - 8
GK35V01		6	H / 3 - 29,53
GK35V01		6	L - 93
GK35G01		6	H / 3 - 119,73
GK35G01		6	L - 146
GK35A01		1	L - 143
GK35A02		4	L - 93
GK35A03		2	V3-45,1
		2	(V3-45,1)*2

CAM /Glass	3	L - 154,8
	3	H / 3 - 91,33

AKSESUARLAR/ Accessories

KOD code	AÇIKLAMA description	ADET unit	TAKIM set
GK-35.01.01	TÜP MOTOR	1	
GK-35.01.02A	TÜP MOTOR BAĞLANTI AKSESUARI	1	
GK-35.01.02B	TÜP MOTOR BAĞLANTI AKSESUARI	1	
GK-35.01.02C	TÜP MOTOR BAĞLANTI AKSESUARI	1	
GK-35.01.03	KASNAK GRUBU		1
GK-35.01.04-1	YAN KAPAKLAR(ÜST)	2	
GK-35.01.04-2	YAN KAPAKLAR(ALT)	2	
GK-35.01.05	ÇELİK HALAT	4	
GK-35.01.06	TAMBUR BORUSU - 6500 mm	1	(L-90)
GK-35.01.11	HALAT TAŞIMA MEKANİZMASI	2	
GK-35.01.07	FİTİL	12	

FİTİLLER/ Gaskets

01.17.25	CAM FİTİLİ		6H*6L
GK-35.01.07	FİTİL (Ø4,5)		12H
GK-35.01.08	ÇİFT TARAFLI RULO BANT		6H*6L
01.19.61	ALT ÜST KASA FİTİLİ	2	L - 143
17.01.03	FİRÇA FİTİL		12V1*3L







MİMARİ KATALOG
ARCHITECTURAL CATALOGUE



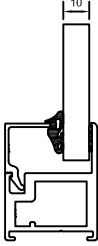

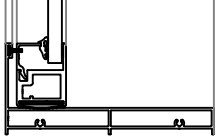
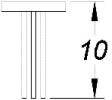
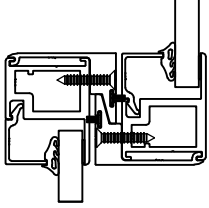

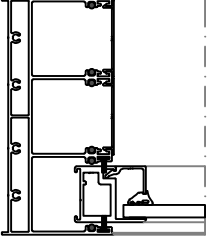

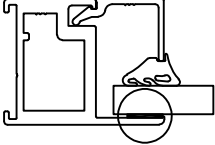

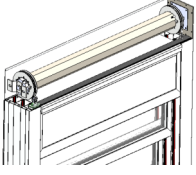
Alüminyum Konvansiyonel Sistemleri
Aluminium Conventional Systems

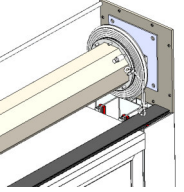
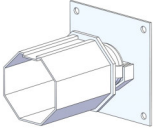
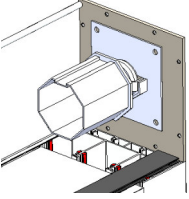
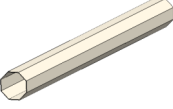
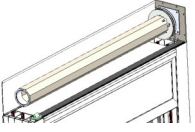
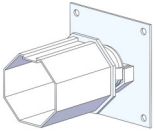
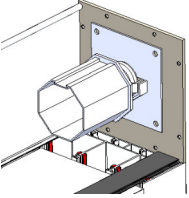
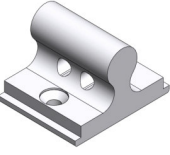
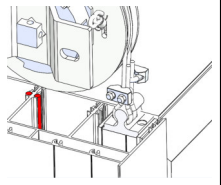
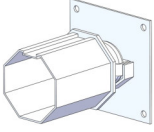
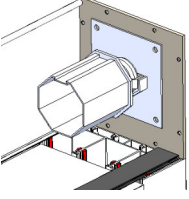

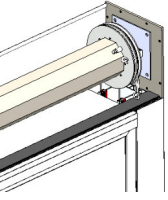

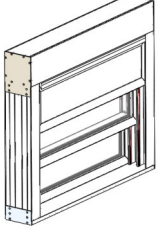
RGK35

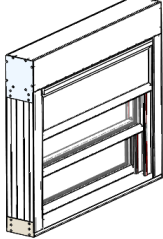
AKSESUARLAR

ACCESSORIES

	<p>01.17.25 İÇ CAM FİTİLİ INSIDE GLAZING GASKET</p> <p>Malzeme / Material : EPDM Ağırlık / Weight : 77 gr/m Paket / Package: 194,8 m / 15 kg</p>				
	<p>01.19.61 ALT ÜST KASA FİTİLİ DOWN UP FRAME GASKET</p> <p>Malzeme / Material : EPDM Ağırlık / Weight : 131 gr/m Paket / Package: 114,5 m / 15 kg</p>				
	<p>17.01.03 KİL FİTİL 67x1000 BRUSH</p> <p>Malzeme / Material Polipropilen / Polipropilene Paket / Package: 250 m</p>				
	<p>GK-35.01.07 PVC PROFİL Ø4,5 PVC PROFILE Ø4,5</p> <p>Malzeme / Material : Polioksimetilen Paket / Package: 3 m</p>				
	<p>GK-35.01.08 ÇİFT TARAFLI RULO BANT DOUBLE SIDED ROLL TAPE</p> <p>10mmx1mm Paket / Package: 50m</p>				

	GK-35.01.01 NATUROLL TÜP MOTOR NATUROLL TUBE MOTOR			GK-35.01.05 ÇELİK HALAT STEEL ROPE Ø3, 4adet x 2,5m Çelik Halat 250 kg dayanıklı	
	GK-35.01.02A TÜP MOTOR BAĞLANTI AKSESUARI TUBE MOTOR CONNECTION ACCESSORIES Paket/Package:1 takım			GK-35.01.06 TAMBUR BORUSU DRUM PIPE 6500 mm	
	GK-35.01.02B TÜP MOTOR BAĞLANTI AKSESUARI TUBE MOTOR CONNECTION ACCESSORIES Paket/Package:1 takım			GK-35.01.11 HALAT TAŞIMA PARÇASI ROPE CARRYING PARTS	
	GK-35.01.02C TÜP MOTOR BAĞLANTI AKSESUARI TUBE MOTOR CONNECTION ACCESSORIES Paket/Package:1 takım			GK-35.01.12 NATUROLL TÜP MOTOR KUMANDASI NATUROLL TUBE MOTOR REMOTE CONTROL	TEK KANALLI VERİCİ TRANSMITTER, SINGLE CHANNEL
	GK-35.01.03 KASNAK GRUBU PULLEY GROUP Paket/Package:1 takım(2 kasnak grubu)			GK-35.01.13 NATUROLL TÜP MOTOR KUMANDASI NATUROLL TUBE MOTOR REMOTE CONTROL	TEK TEK VEYA GRUP KONTROL ÖZELLİĞİ OLAN 4 KANALLI VERİCİ TRANSMITTER, 4 CHANNELS, INDIVIDUAL AND GROUP CONTROL FUNCTION
	GK-35.01.04-1 YAN KAPAKLAR(üst) SIDE CAPS			GK-35.01.14 NATUROLL TÜP MOTOR KUMANDASI NATUROLL TUBE MOTOR REMOTE CONTROL	TEK TEK VEYA GRUP KONTROL ÖZELLİĞİ OLAN LCD EKРАНLI 4 KANALLI VERİCİ TRANSMITTER, 4 CHANNELS, LCD DISPLAY, INDIVIDUAL AND GROUP CONTROL FUNCTION
	GK-35.01.04-2 YAN KAPAKLAR(alt) SIDE CAPS			GK-35.01.15 NATUROLL TÜP MOTOR KUMANDASI NATUROLL TUBE MOTOR REMOTE CONTROL	TEK TEK VEYA GRUP KONTROL ÖZELLİĞİ OLAN LCD EKРАНLI 8 KANALLI VERİCİ TRANSMITTER, 8 CHANNELS, LCD DISPLAY, INDIVIDUAL AND GROUP CONTROL FUNCTION

	<p>GK-35.01.16</p> <p>NATUROLL TŪP MOTOR KUMANDASI NATUROLL TUBE MOTOR REMOTE CONTROL</p>	<p>TEK TEK VEYA GRUP KONTROL ÖZELLİĞİ OLAN LCD EKРАНLI 16 KANALLI VERİCİ TRANSMITTER, 16 CHANNELS, LCD DISPLAY, INDIVIDUAL AND GROUP CONTROL FUNCTION</p>			
	<p>GK-35.01.17</p> <p>NATUROLL TŪP MOTOR KUMANDASI NATUROLL TUBE MOTOR REMOTE CONTROL</p>	<p>TEK KANALLI 8 FARKLI AÇMA KAPAMALI ZAMAN AYARLAYICI LCD EKРАНLI VERİCİ TRANSMITTER, SINGLE CHANNEL, LCD DISPLAY, TIMER FUNCTION, 8 DIFFERENT OPEN&CLOSE TIME</p>			
	<p>GK-35.01.18</p> <p>NATUROLL TŪP MOTOR KUMANDASI NATUROLL TUBE MOTOR REMOTE CONTROL</p>	<p>TEK TEK VEYA 4 KANALLI 8 FARKLI AÇMA KAPAMALI ZAMAN AYARLAYICI LCD EKРАНLI VERİCİ TRANSMITTER, 4 CHANNELS, LCD DISPLAY, TIMER FUNCTION, 8 DIFFERENT OPEN&CLOSE TIME</p>			
	<p>GK-35.01.19</p> <p>NATUROLL TŪP MOTOR KUMANDASI ALICISI NATUROLL TUBE MOTOR REMOTE CONTROL RECEIVER</p>	<p>GARAJ TİPİ DUVAR ALICI RECEIVER FOR GARAGE DOOR APPLICATION</p>			

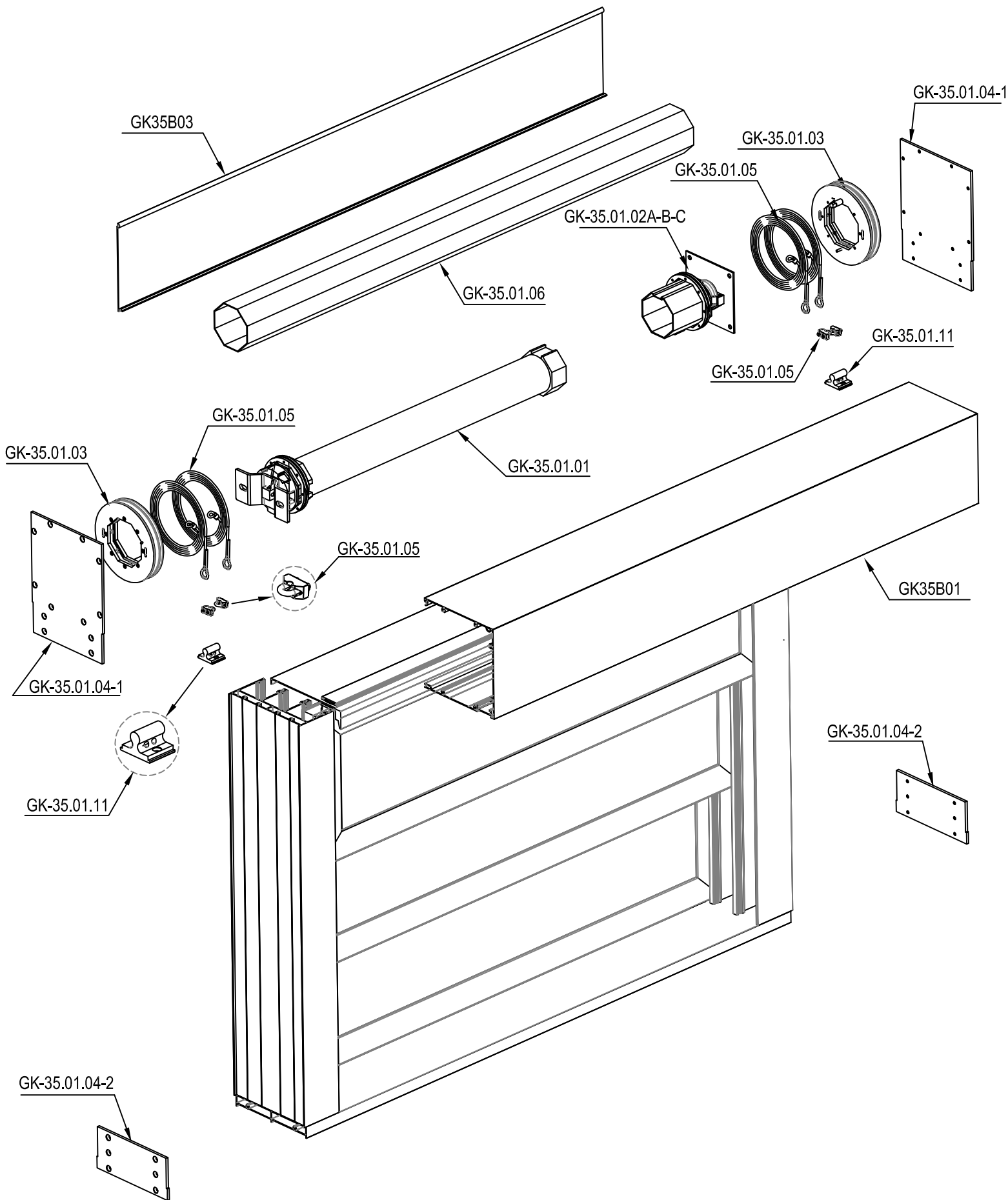

HAREKET MEKANİZMASI SETİ
MOVEMENT MECHANISM SET

	KOD CODE	TANIM DESCRIPTION	ADET NUMBER	TAKIM SET
1	GK-35.01.01	TÜP MOTOR TUBE MOTOR	1	
2	GK-35.01.02A	TÜP MOTOR BAĞLANTI AKSESUARI TUBE MOTOR CONNECTION ACCESSORIES		1
3	GK-35.01.02B	TÜP MOTOR BAĞLANTI AKSESUARI TUBE MOTOR CONNECTION ACCESSORIES		1
4	GK-35.01.02C	TÜP MOTOR BAĞLANTI AKSESUARI TUBE MOTOR CONNECTION ACCESSORIES		1
5	GK-35.01.03	KASNAK GRUBU PULLEY GROUP		1
6	GK-35.01.04-1	YAN KAPAKLAR(ÜST) SIDE CAPS (UP)	2	
7	GK-35.01.04-2	YAN KAPAKLAR(ALT) SIDE CAPS (DOWN)	2	
8	GK-35.01.05	ÇELİK HALAT STEEL ROPE	4	
9	GK-35.01.06	TAMBUR BORUSU - 6500 mm DRUM PIPE - 6500 mm	1	
10	GK-35.01.11	HALAT TAŞIMA MEKANİZMASI ROPE CARRYING MECHANISM	2	
11	GK-35.01.07	FİTİL GASKET	12	